

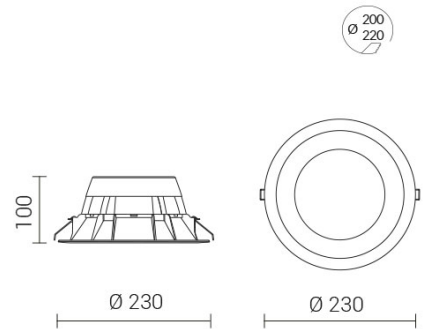

# HALL LED ESSENTIAL Large

IP54 protection from the bottom

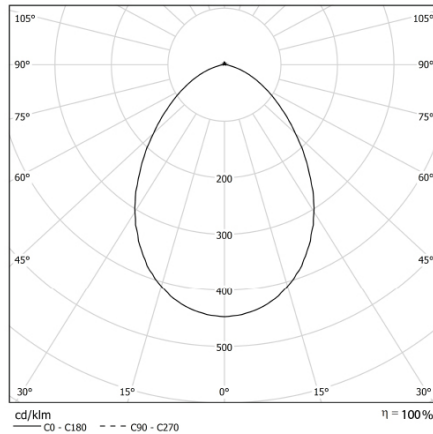

CODE		FLUX	SIZE	CERTIFICATIONS
38MP26K4L54D	26W 4000K	3780lm	230mm	   

## Optics

Microcell polycarbonate internal reflector and opal microprism polycarbonate diffuser. UGR<19.

## Body

Polycarbonate body and die-cast aluminum heat sink.

## Specifications

SMD LED technology;  
Driver included;  
CRI>90;  
Mac Adams 3;  
Life Time: L80/B10 >50.000h;  
5 years complete warranty;  
Eye safety: RG0/RG1 in accordance with EN62471:2009

## Legal references

In compliance with the safety standards EN 60 598-1 and UNI EN 12464-1 (lighting for working places).

## Wiring

D: Standard wiring is 220-240V, DALI dimmable